

HARRISTM

Siphon Breaker and Air Relief Valve

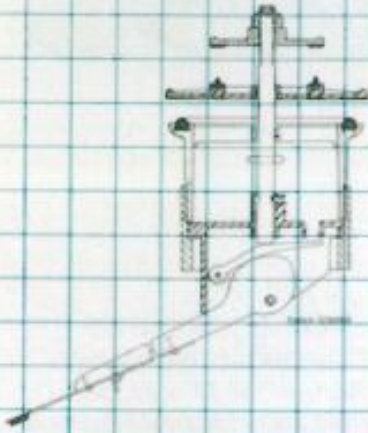

For Reliability
For Efficiency
For Economy
For Safety

The HarrisTM Siphon Breaker & Air Relief Valve is designed to control the natural siphon action of drainage pump station pipelines. It is the only valve of its type with over 60 years of proven market experience. During that time, Harris Siphon Breaker & Air Relief Valves have provided years of trouble-free service to government entities and private individuals both nationwide and overseas.

It offers:

- Increased pump efficiency
- Controlled siphon action
- Positive siphon break
- Pump back wash
- Reasonable prices

MANUFACTURED AND
DISTRIBUTED BY --

DURHAM PUMP, INC.

TURBINE PUMPS — IRRIGATION SYSTEMS

Mailing Address: PO Box 60 Durham, CA 95938

530-891-4821

www.durhampump.com

Contractor's Lic #271327

Harris™ Siphon Breaker & Air Relief Valve

Valve Sizing

The Harris Siphon Breaker & Air Relief Valve is available in five sizes. To determine the size needed for your application you need to find:

- the inside diameter of the pipe
- the volume (GPM) or velocity (CM) of flow
- the elevation difference between lowest water and highest pipe centerline (see figure 1).

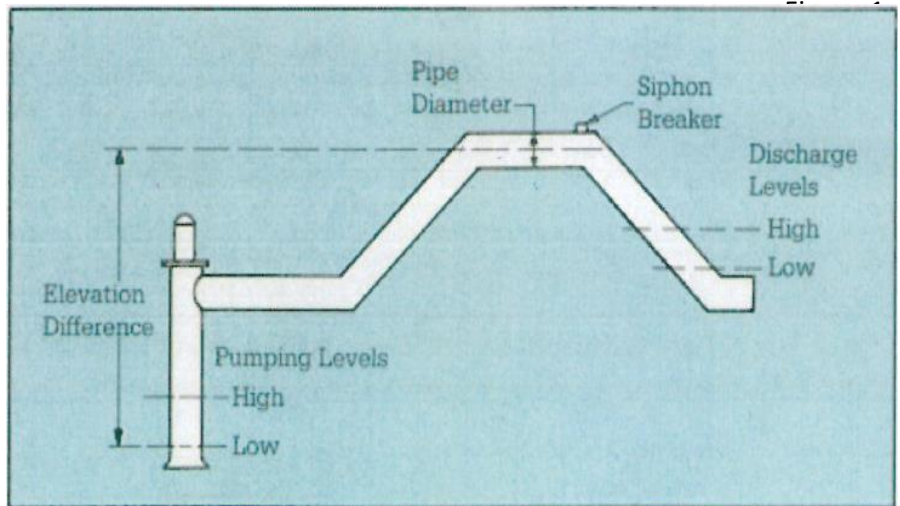

Harris valves can be fitted with arms to operate within a range of pipe sizes (figure 3). Since there is some overlap in size, the flow rate chart (figure 2) is used to identify the best valve for the application. To use figure 2 you need to know the cubic feet per second (CFS) flow. If you know the gallons per minute (GPM) you can convert to CFS by dividing by 450.

Locate the CFS of your installation on the bottom line of figure 2. Lay a straight edge perpendicular at that spot and see which valve performance line is crossed. Select the smallest valve possible for that

- Inside diameter of pipeline in inches
- Volume (GPM) or Velocity (CFS)
- Difference between low water and highest pipe centerline

flow which also falls at or below the optimum air velocity of 300 F.P.S.

Example 1:
Assume a 30" line with 50 CFS velocity flow. A 7", 8", or 12" valve could work but since the 7" valve is the smallest valve under 300 FPS (figure 2) it would be most economical.

Example 2:
Assume a 48" line with 225 CPS. In this case the optimum capacity of the 12" valve is exceeded and additional vent type valves would be required. $225 - 185$ (optimum) = 40. 40 CFS would require a 7" vent valve ahead of the 12" valve in the line.

Figure 2

Harris Valve Sizing —

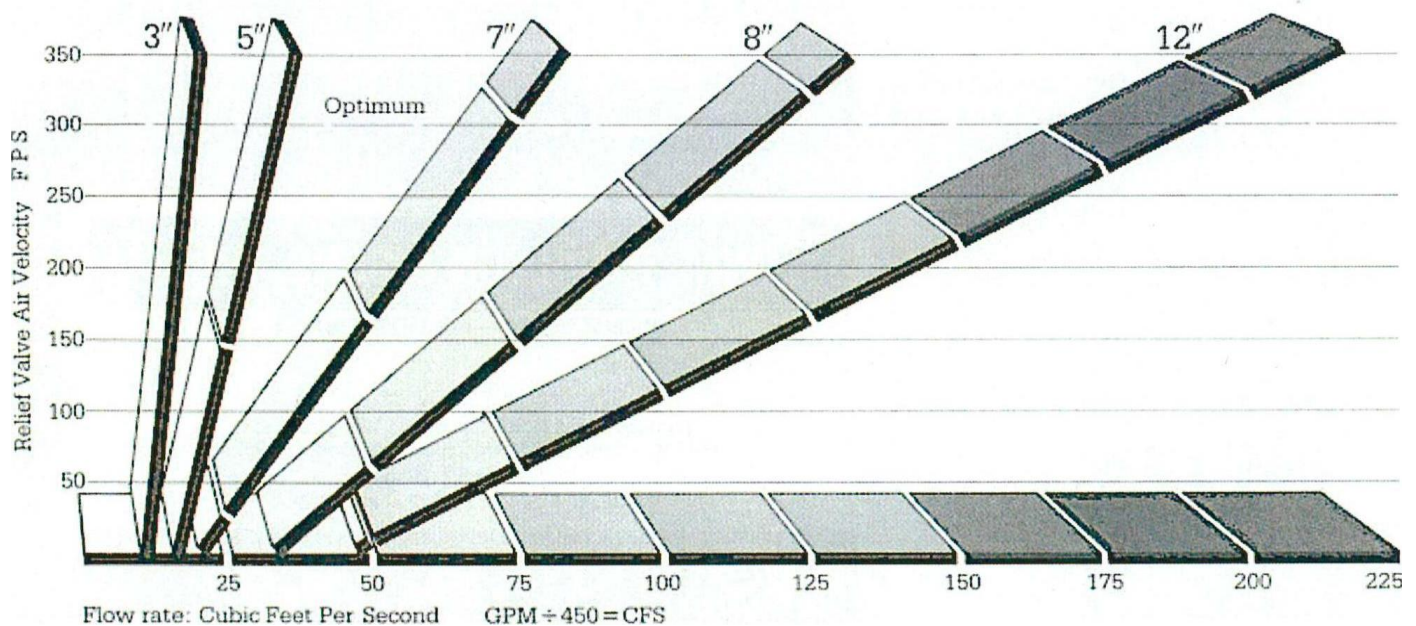

Use the elevation difference and figure 4 to determine the siphon vent area of the cover for the size valve you have selected. The model number of the valve is in the left-hand column. Add a dash and the pipe size in inches and you have a complete description for ordering.

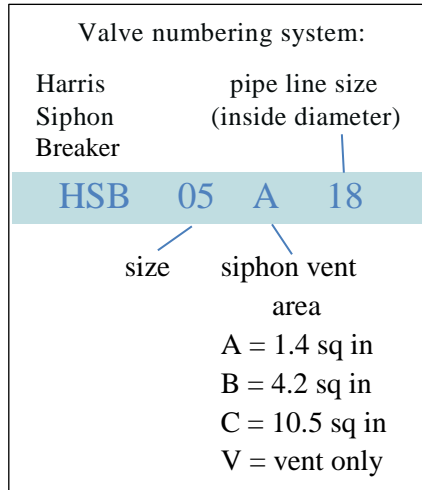

Figure 4

Model #	Base Size	Allowable Elev. Diff.	AirVent Area	Siphon Vent
HSB 03 A	3"	all	4.2sq. in.	1.4 sq.in
	B*	10'	4.2	4.2
HSB 05 A	5"	all	10.5	1.4
	B	16'	10.5	4.2
	C	10'	105	10.5
HSB 07 B	7"	all	26.5	4.2
	C	15'	26.5	10.5
HSB 08 B	8"	all	40.0	4.2
	C	15'	40.0	10.5
HSB 12 C	12"	all	92.0	10.5

*one piece cover.

Valve Dimensions NOTE: See Figure 5

Number on Drawing	3"	5"	7"	8"	12"	
1	4"	6 1/4"	9 1/8"	10 1/8"	14 3/4"	OD of largest part
2	7 3/4"	10 1/2"	14"	14 1/4"	15 1/2"	full open
3	2"	3"	4"	4"	4"	height of steel base ring
4	3 1/2"	5 5/8"	7 3/4"	8 5/8"	12 3/4"	OD of steel base ring

The above sizes are minimum for proper installation and operation of Harris Siphon Breaker & Air Relief Valves

Figure 3

3" for pipelines 8" to 14" in diameter
5" for pipelines 12" to 22" in diameter
7" for pipelines 16" to 36" in diameter
8" for pipelines 24" to 48" in diameter
12" for pipelines 30" to 72" in diameter

Harris™ Siphon Breaker & Air Relief Valves Standard Construction

- Valve Body - Gray iron casting, painted
- Weight - Gray iron casting, cold galvanized
- Spider, cam, & finger - Bronze castings
- Arm - Manganese bronze
- Taper pin - stainless steel
- Valve Stem & Hinge Pins - stainless steel

- Base Ring - Extra heavy pipe or tubing
- Vane - Half hard sheet brass
- Screws & Lock Nut - Brass or stainless steel
- Valve Seat (Gasket) - Neoprene. special formula
- Valve Cover(s) - Brass

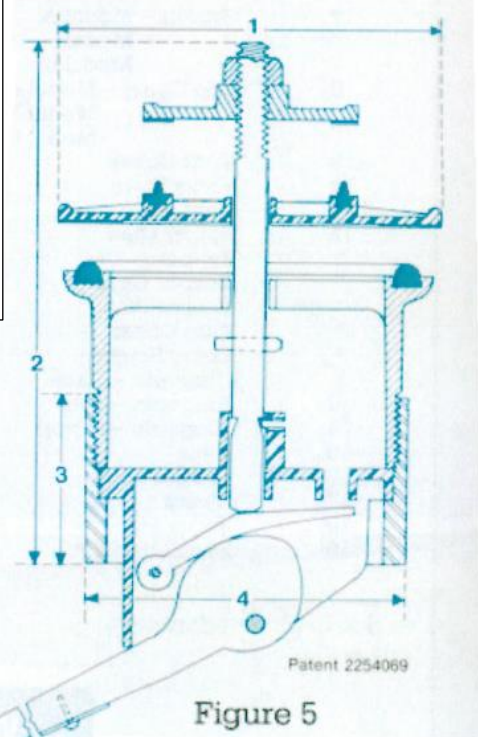

Harris™ Siphon Breaker & Air Relief Valve Typical Installation

- 1 Locate Installation point approximately one to two pipe diameters before the highest break point on the discharge line
- 2 Cut hole in pipe to accept the base ring.
- 3 Weld the steel base ring in place. Top of base ring must be level

4. Insert bronze spider unit with arm into base ring. Arrow on spider unit must point in direction of flow when pumping.
- 5 Remove cover from valve body. coat. threads on valve body with pipe dope, thread body into base ring and tighten. Be sure spider unit does not turn (it is usually necessary to turn spider unit so that arrow points slightly to left of center before starting to tighten valve body.)

- 6 Replace valve cover and adjust opening to allow approximately Ye to Yr gap between cover and gasket with arm hanging free. Install and tighten locknut.

NOTE:

Full instructions for installation of the valve and adjustment of the cover are sent with each valve Proper adjustment is essential for proper operation of the valve.

Harris™ Valve Parts List

ITEM NO.		3"	5"	7"	8"	12"
1	Base Ring	010-03	010-05	010-07	010-08	010-12
2a	Spider & Arm Assem	370-03	380-05	390-07	391 08	395-12
2	Spider	070-03	080-05	090-07	091-08	095-12
3a	Arm Ass=	123-XX	145-XX	137-XX	138-XX	172-XX
3	Arm - Regular	020-XX	040-XX	030-X'X	030-XX	107-XX
	Extra Long		041-XX	042-XX	042-XX	106-XX
4	Body	300-00	500-00	700-00	800-00	120-00
5	Body Gasket	300-01	500-01	703-01	800-01	120-01
6	Valve-Cover - Model A	032-03	052-05			
	Model B	033-03	053-05	072-07	082-08	
	Model C		051-05	073-07	083-08	120-12
7	Gasket - Model A	300-34	300-34			
	Model B	300-01	300-01	300-01	300-01	
	Model C		500-01	500-01	500-01	500-01
8	Top Cover - Model A	031-03	031-05			
	Model B	033-03	033-05	033 07	033-08	
	Model C		051-05	051-07	051-08	051-12
9	Vent Cover	033-03	051-05	071-07	081-08	121-12
10	Valve Stem	100-03	100-05	100-07	100-08	100-12
11	Vent Stem	110-03	110-05	110-07	110-08	110-12
12	Finger Cam	002-03	010-05	060-07	060-08	060-12
13	Hingepin - Arm	1/4 x 1-3/8	3/8 x 1-3/8	3/8 x 1-3/8	3/8X 1-3/8	3/8x 1-3/8
14	Hingepin - Finger	118 x 3/8	3/16 x 1-3/8	1/4 x 1-5/8	1/4 x 1-5/8	1/4x 1-6/8
15	Vane	210-XX	210-XX	210-XX	210-XX	210-XX
16	Weight	220-03	220-05	420-07	420-08	420-12
17	Rivets	3/16 x 2	3/16 x 2	1/4 x 2	114 x 2	1/4 x 2
18	Taper Pin	240-03	240-05	240-07	240-07	240-12
19	Stem Lock Nut	3/8-NC	1/2-NC	5/8-NC	5/8-NC	3/4-NC

See exploded drawing, next page.

MANUFACTURED AND DISTRIBUTED BY —

DURHAM PUMP, INC.

530-891-4821

www.durhampump.com

Contractor's Lic #271327

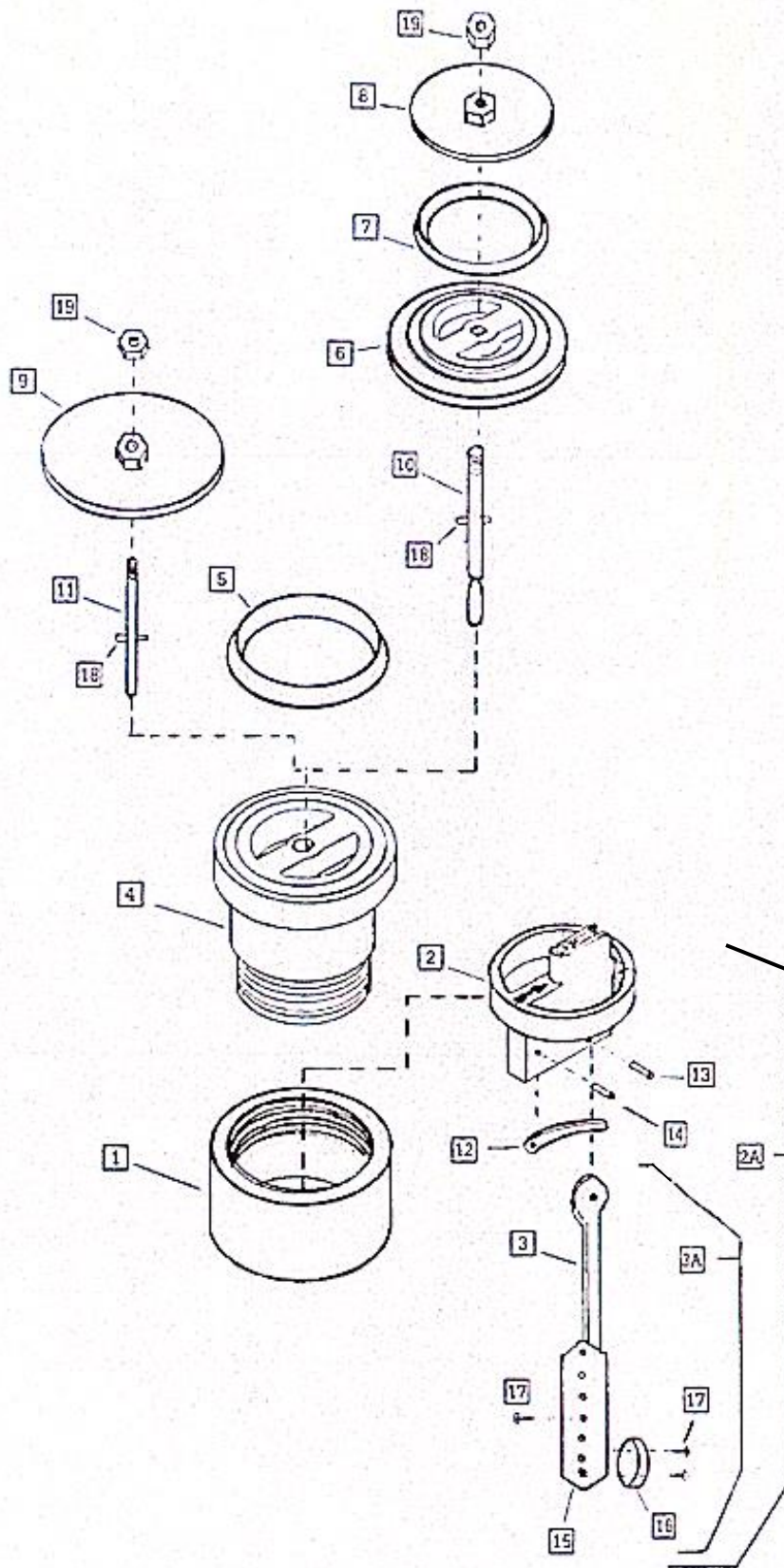

**Harris™ Valve
Parts Breakdown**

**2A-Spider & Arm Assy
3A-Arm & Vane Assy**